

CELMA
indukta

Trójfazowe silniki klatkowe
wysokosprawne seria
3SIE (IE3)



Cantoni[®]
GROUP

KATALOG PRODUKTÓW

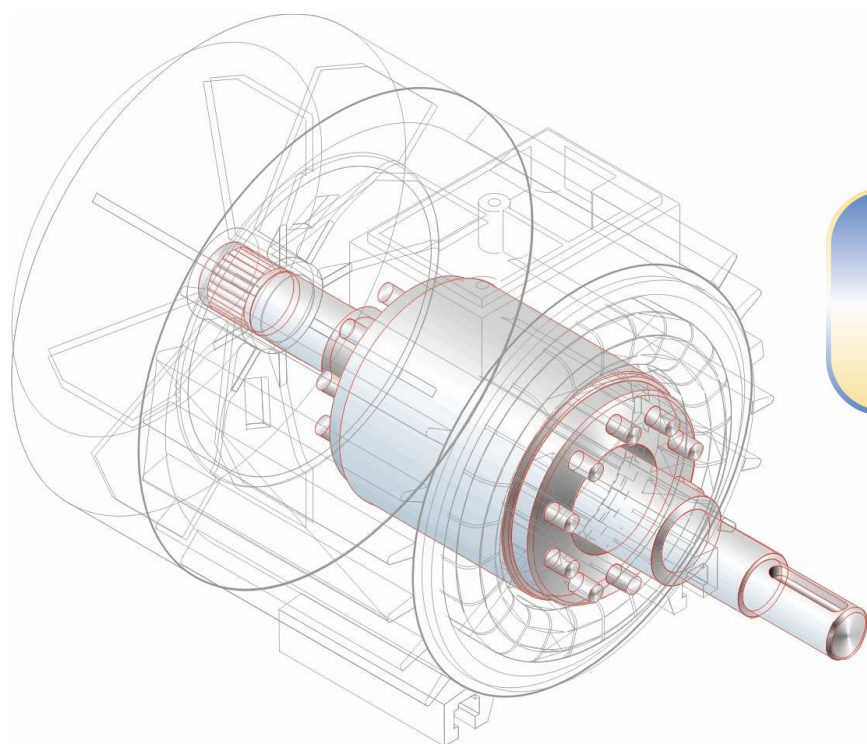

since 1920



since 1878

**TRÓJFAZOWE SILNIKI INDUKCYJNE
Z WIRNIKIEM KLATKOWYM O WYSOKIEJ
SPRAWNOŚCI W KLASIE IE3
WIELKOŚCI MECHANICZNEJ 90÷315**

**PREMIUM EFFICIENCY IE3
THREE-PHASE INDUCTION MOTORS
WITH SQUIRREL-CAGE ROTOR
SIZE 90÷315**

EDITION 4

CELMA INDUKTA Spółka Akcyjna

Siedziba Główna i Zakład Produkcyjny Nr 1: 43-400 Cieszyn ul. 3 Maja 19 tel.: (48 33) 47 01 700, fax.: (48 33) 47 01 806

Zakład Produkcyjny Nr 2: 43-346 Bielsko-Biała ul. Chochołowska 21 tel.: (48 33) 47 01 400, fax.: (48 33) 81 25 018

e-mail: celmaindukta@cantonigroup.com

www.cantonigroup.com

SILNIKI WYSOKOSPRAWNE PREMIUM IE3

PREMIUM EFFICIENCY MOTORS IE3

Zastosowanie:

- przeznaczenie ogólne,
- miejsce pracy: wewnątrz i na zewnątrz pomieszczeń,
- otoczenie: bez zagrożenia wybuchem, bez mgły solnej i substancji agresywnych wywołujących korozję.

Charakterystyka wykonania:

- moce znamionowe podane są dla pracy S1,
- napięcie znamionowe 230Δ/400YV lub 400Δ/690YV,
- częstotliwość napięcia zasilania 50 [Hz],
- temperatura otoczenia do +40[°C],
- wysokość instalowania do 1000 [m] n.p.m.,
- wilgotność względna 95%,
- izolacja klasy F (155°C),
- czujniki PTC uzwojenia: standard dla w.m. 200...315,
- stopień ochrony IP 55,
- kolor malowania RAL 5010,
- z jednym czopem końcowym wału wg rysunku wymiarowego,
- skrzynka zaciskowa z dławnicami i tabliczką 6-zaciskową.

Silniki spełniają wymagania norm:

- IEC 60034-1- Maszyny elektryczne wirujące- Część 1-Dane znamionowe i parametry,
- PN-EN-60034-30-1:2014 – Klasy sprawności silników prądu przemiennego bezpośrednio zasilanych z sieci (kod IE),
- PN-EN-60034-2-1:2014 –Znormalizowane metody wyznaczania strat i sprawności na podstawie badań.

Wykonania na życzenia:

- z termistorowymi czujnikami PTC dla w.m. 90...180 lub bimetalowymi wyłącznikami temperatury zabudowanymi w uzwojeniu,
- z czujnikami temperatury łożysk,
- izolacja klasy H,
- stopień ochrony max. IP66,
- podgrzewacze uzwojenia,
- przystosowane do pracy w klimacie tropikalnym TH, TA lub MT ,
- z hamulcem elektromagnetycznym,
- z obcym chłodzeniem,
- z enkoderem,
- ze specjalnym końcem wału,
- z dwoma walcowymi czopami wału wg rysunku wymiarowego,
- fabryka wykonuje również silniki różniące się od wykonania podstawowego po uprzednim uzgodnieniu szczegółów konstrukcyjnych i terminów dostaw.

Sposób zamawiania:

- W zamówieniu należy podać pełne określenie typu silnika, moc, prędkość obrotową, napięcie zasilające, układ połączeń, częstotliwość formę wykonania oraz inne szczegóły niekatalogowego lub specjalnego wykonania.

Wszystkie silniki posiadają znak CE.

Application:

- general purpose,
- operation place: indoors and outdoors,
- environment: without explosive conditions, without salt mist, without aggressive corrosive substances.

Features:

- rated output for continuous duty S1,
- rated voltage 230Δ/400YV lub 400Δ/690YV,
- frequency 50 [Hz],
- environment temperature up to +40[°C],
- altitude up to 1000 [m] above sea level,
- relative humidity 95%,
- insulation class F (155°C),
- PTC sensors in winding: standard in size 200...315,
- protection degree IP 55,
- standard paint color RAL 5010,
- one free shaft extension according to dimension drawing,
- terminal box with glands and 6 terminals.

Motors meet requirements of standards:

- IEC 60034-1- Rotating electrical machines – Part 1: Rating and performance,
- IEC 60034-30-1:2014 – Efficiency classes of line operated AC motors (IE Code),
- IEC 60034-2-1:2014 – Standard methods for determining losses and efficiency from test.

Features on request:

- with PTC temperature sensors in size 90...180 or with bimetallic thermal switches in the winding ends,
- with temperature sensors in bearing shields,
- insulation class H,
- protection degree max. IP66,
- winding heaters,
- fit for work in tropical climate TH, TA or MT,
- electromagnetic brake,
- external cooling,
- encored,
- special shaft extension,
- two cylindrical shaft extension according to dimension drawing,
- factory produces various types of motors but constructional details and delivery time are to be individual agreed.

How to order:

- In the order there must be clearly given: full designation of the motor, rated output, rated speed, rated voltage, phase connection, frequency, mounting form and all other details for non catalogue execution.

All motors are provided with CE mark.

PARAMETRY EKSPLOATACYJNE SILNIKÓW
PERFORMANCES OF MOTORS

Typ silnika	Moc znamionowa P _N		Parametry przy obciążeniu znamionowym: Data of rated load:									Krotność (przy włączeniu bezpośrednim): Ratio of (at direct switching on):			Moment bezwładności wirnika J _M	Masa IM B3	Poziom mocy akustycznej przy 50Hz L _{WA}	Poziom ciśnienia akustycznego przy 50Hz L _{PA}			
			Prędkość n _N	Sprawność [%] η _N * IE3			Moment M _N	Współczynnik mocy cos φ _N	Prąd znamionowy [A] I _N			Prądu rozruchowego do znamionowego I _r /I _N	Momentu rozruchowego do znamionowego M _r /M _N	Momentu maksymalnego do znamionowego M _b /M _N							
Type of motor	Rated output P _N	Speed n _N		Efficiency [%] η _N * IE3					Torque T _N	Power factor cos φ _N	Rated current [A] I _N				Starting current to rated current I _r /I _N	Starting torque to rated torque T _r /T _N	Break-down torque to rated torque T _b /T _N	Moment of inertia of rotor J _M	Weight IM B3	Noise power level at 50Hz L _{WA}	Noise pressure level at 50Hz L _{PA}
			[kW]	[HP]	[min ⁻¹]	50%	75%	100%			[Nm]	[-]	230V Δ	380V**							
Silniki 2-biegunowe, prędkość synchroniczna 3000 min ⁻¹ przy 50Hz																			2-pole motors, synchronous speed 3000 min ⁻¹ at 50Hz		
3SIE90S2	1,5	2,0	2925	82,7	84,4	84,2	4,9	0,85	5,3	3,2	3,0	7,3	2,4	3,5	0,0014	16,5	75	63			
3SIE90L2	2,2	3,0	2910	85,4	86,5	85,9	7,2	0,86	7,5	4,5	4,3	8,0	2,7	4,0	0,0019	18,5	75	63			
3SIE100L2	3,0	4,0	2915	86,9	87,7	87,1	9,8	0,85	10,2	6,2	5,8	8,5	3,1	4,1	0,0039	25	74	62			
3SIE112M2	4,0	5,5	2925	88,7	89,0	88,1	13,0	0,89	12,8	7,8	7,4	8,4	2,3	3,2	0,0075	35,5	74	61			
3SIE132S2A	5,5	7,5	2940	87,7	89,2	89,2	17,9	0,89	17,4	10,5	10,0	8,2	2,6	3,4	0,014	55	80	68			
3SIE132S2B	7,5	10,0	2940	89,0	90,3	90,1	24,4	0,90	23,2	14,1	13,3	8,5	2,8	3,8	0,017	64	80	68			
3SIE160M2A	11,0	15,0	2945	90,3	91,4	91,2	35,7	0,90	33,6	20,4	19,3	7,9	2,1	3,2	0,048	123	82	69			
3SIE160M2B	15,0	20,0	2945	89,8	91,9	91,9	48,6	0,90	45,5	27,6	26,2	8,0	2,4	3,3	0,059	132	82	69			
3SIE160L2	18,5	25,0	2940	92,2	92,8	92,4	60,1	0,90	55,8	33,8	32,1	7,7	2,3	3,0	0,072	139	82	69			
3SIE180M2	22,0	30,0	2955	91,1	92,4	92,7	71,1	0,90	66,2	40,1	38,1	9,2	3,2	3,7	0,095	190	88	75			
3SIE200L2A	30,0	40	2965	93,1	93,7	93,5	97	0,90	89	54	51	7,0	2,4	2,8	0,19	275	88	78			
3SIE200L2B	37,0	50	2955	93,5	93,8	93,7	120	0,90	110	67	63	6,3	2,2	2,6	0,20	295	88	78			
3SIE225M2	45,0	60	2972	94,2	94,6	94,2	145	0,88	136	82	78	6,7	2,0	2,6	0,26	385	90	80			
3SIE250M2	55,0	75	2969	94,5	94,8	94,5	177	0,91	161	97	92	6,9	2,2	2,9	0,42	495	87	77			
3SIE280S2	75,0	100	2978	94,2	94,8	94,7	241	0,91	218	132	126	6,7	1,8	2,9	0,76	660	87	77			
3SIE280M2	90,0	125	2979	94,5	95,1	95,0	289	0,91	261	158	150	7,3	1,8	3,1	0,95	690	92	82			
3SIE315S2	110,0	150	2978	95,4	95,6	95,2	353	0,92	315	191	181	6,9	1,9	2,9	0,98	865	87	77			
3SIE315M2A	132,0	175	2977	95,8	95,9	95,6	423	0,92	377	228	217	7,3	2,0	2,7	1,28	970	89	78			
3SIE315M2B	160,0	220	2978	95,9	96,1	95,8	513	0,92	456	276	262	8,2	2,2	3,1	1,57	1118	89	78			
3SIE315M2C	200,0	270	2980	95,9	96,1	95,8	641	0,93	-	341	324	8,1	2,3	3,1	1,74	1185	96	86			
Silniki 4-biegunowe, prędkość synchroniczna 1500 min ⁻¹ przy 50Hz																			4-pole motors, synchronous speed 1500 min ⁻¹ at 50Hz		
3SIE90S4	1,1	1,5	1450	81,8	84,0	84,1	7,2	0,77	4,3	2,6	2,5	7,2	2,3	3,5	0,0036	18	66	54			
3SIE90L4	1,5	2,0	1450	83,9	85,5	85,3	9,9	0,78	5,7	3,4	3,3	7,4	2,5	3,4	0,0040	21	66	54			
3SIE100L4A	2,2	3,0	1465	85,0	86,8	86,7	14,3	0,80	8,0	4,8	4,6	7,5	2,3	2,9	0,0076	27,5	67	55			
3SIE100L4B	3,0	4,0	1465	85,8	87,7	87,7	19,6	0,79	10,9	6,6	6,3	7,4	2,5	3,5	0,0086	31	67	55			
3SIE112M4	4,0	5,5	1455	88,5	89,0	88,6	26,3	0,80	14,2	8,6	8,1	7,0	2,1	3,0	0,0115	41,5	70	58			
3SIE132S4	5,5	7,5	1465	89,5	90,0	89,6	35,7	0,85	18,1	11,0	10,4	8,5	2,5	3,4	0,036	63	72	59			
3SIE132M4	7,5	10,0	1465	89,7	90,6	90,4	49,1	0,83	25,1	15,2	14,4	8,8	2,9	3,8	0,042	67	72	59			
3SIE160M4	11,0	15,0	1470	90,9	91,7	91,4	71,5	0,83	36,4	22,0	20,9	7,3	2,6	2,8	0,088	136	74	61			
3SIE160L4	15,0	20,0	1475	92,0	92,5	92,1	97,1	0,83	49,3	29,8	28,3	8,1	2,7	3,2	0,104	154	74	61			
3SIE180M4	18,5	25,0	1475	91,4	92,5	92,6	120,2	0,85	59,0	35,7	33,9	8,3	2,9	3,0	0,162	190	75	62			
3SIE180L4	22,0	30,0	1475	91,4	92,8	93,0	142,4	0,83	71,5	43,3	41,1	8,5	3,2	3,4	0,185	200	76	63			
3SIE200L4	30,0	40	1477	94,2	94,3	93,8	194	0,89	90	55	52	6,4	2,1	2,6	0,38	329	80	70			
3SIE225S4	37,0	50	1485	94,1	94,4	94,0	238	0,87	114	69	65	6,9	2,0	2,8	0,51	373	73	63			
3SIE225M4	45,0	60	1483	94,4	94,8	94,3	290	0,88	136	82	78	7,1	2,1	2,7	0,59	410	73	63			
3SIE250M4	55,0	75	1487	94,0	94,8	94,7	353	0,90	162	98	93	7,6	2,5	2,9	1,00	520	85	75			
3SIE280S4	75,0	100	1488	93,9	95,0	95,0	481	0,91	218	132	125	6,8	2,0	2,5	1,37	710	87	77			
3SIE280M4	90,0	125	1491	94,9	95,5	95,4	576	0,89	266	161	153	8,4	2,6	3,0	1,80	761	87	77			
3SIE315S4	110,0	150	1488	95,1	95,5	95,4	706	0,90	322	195	185	6,6	2,0	2,4	2,25	920	85	75			
3SIE315M4A	132,0	175	1489	95,6	95,9	95,6	847	0,91	381	231	219	7,9	2,3	2,8	2,59	1030	86	76			
3SIE315M4B	160,0	220	1490	95,9	96,1	95,8	1026	0,90	466	282	268	8,5	2,4	3,1	2,80	1130	87	77			
3SIE315M4C	200,0	270	1488	95,8	96,2	96,2	1284	0,90	-	351	333	8,1	2,4	2,9	3,46	1205	92	82			

PARAMETRY EKSPLOATACYJNE SILNIKÓW
PERFORMANCES OF MOTORS

Typ silnika	Moc znamionowa P _N	Parametry przy obciążeniu znamionowym: Data of rated load:									Krotność (przy włączeniu bezpośrednim): Ratio of (at direct switching on):			Moment bezwładności wirnika J _m	Masa IM B3	Poziom mocy akustycznej przy 50Hz L _{WA}	Poziom ciśnienia akustycznego przy 50Hz L _{pA}	
		Prędkość n _n	Sprawność [%] η _N IE3*			Moment M _n	Współczynnik mocy cos φ _N	Prąd znamionowy [A] I _N			Prądu rozruchowego do znamionowego I _r /I _N	Momentu rozruchowego do znamionowego M _r /M _N	Momentu maksymalnego do znamionowego M _b /M _N					
Type of motor	Rated output P _N	Speed n _n	Efficiency [%] η _N IE3*			Torque T _N	Power factor cos φ _N	Rated current [A] I _N			Starting current to rated current I _r /I _N	Starting torque to rated torque T _r /T _N	Break-down torque to rated torque T _b /T _N	Moment of inertia of rotor J _m	Weight IM B3	Noise power level at 50Hz L _{WA}	Noise pressure level at 50Hz L _{pA}	
			[kW]	[HP]	[min ⁻¹]			50%	75%	100%								[Nm]
Silniki 6-biegunowe, prędkość synchroniczna 1000 min ⁻¹ przy 50Hz 6-pole motors, synchronous speed 1000 min ⁻¹ at 50Hz																		
3SIE90S6	0,75	1,0	940	77,2	79,3	78,9	7,6	0,70	3,4	2,1	2,0	4,3	1,7	2,4	0,0032	16	62	50
3SIE90L6	1,1	1,5	940	79,9	81,9	81,0	11,1	0,70	4,9	2,9	2,8	4,5	2,1	2,6	0,0090	19	62	50
3SIE100L6	1,5	2,0	960	81,1	82,8	82,5	14,9	0,74	6,2	3,7	3,5	6,2	2,6	3,3	0,0100	23,5	64	52
3SIE112M6	2,2	3,0	965	83,9	84,9	84,3	21,8	0,76	8,6	5,2	5,0	5,9	2,1	2,6	0,0177	34	65	53
3SIE132S6	3,0	4,0	965	86,8	87,8	87,0	29,7	0,81	10,7	6,5	6,2	6,6	2,2	2,9	0,0440	54	67	55
3SIE132M6A	4,0	5,5	965	89,1	89,2	88,0	39,8	0,81	14,1	8,5	8,1	6,6	2,3	3,0	0,0579	62	70	58
3SIE132M6B	5,5	7,5	960	88,9	89,1	88,0	54,7	0,81	19,4	11,7	11,1	6,7	2,4	3,1	0,0637	66	73	61
3SIE160M6	7,5	10,0	970	89,0	89,9	89,5	73,8	0,82	25,7	15,5	14,8	6,8	2,1	2,9	0,102	134	74	61
3SIE160L6	11,0	15,0	970	91,0	91,0	90,3	108,3	0,82	37,3	22,6	21,4	7,0	2,2	3,0	0,123	146	74	61
3SIE180L6	15,0	20,0	980	90,0	91,3	91,2	146,2	0,81	51,0	30,9	29,3	7,3	3,3	2,8	0,276	198	74	61
3SIE200L6A	18,5	25	988	91,3	92,0	91,7	179	0,81	63	38	36	5,8	2,0	2,4	0,50	285	74	64
3SIE200L6B	22,0	30	987	91,7	92,2	92,2	213	0,82	73	44	42	5,7	2,0	2,1	0,64	309	74	64
3SIE225M6	30,0	40	989	92,3	92,9	92,9	290	0,83	98	59	56	6,4	1,9	2,3	0,89	392	74	64
3SIE250M6	37,0	50	991	92,2	93,4	93,3	357	0,82	121	73	70	6,7	2,0	2,6	1,23	440	76	66
3SIE280S6	45,0	60	993	92,9	93,8	93,7	433	0,81	149	90	86	7,3	2,3	2,6	1,70	635	76	66
3SIE280M6	55,0	75	992	93,8	94,4	94,1	529	0,82	179	108	103	6,8	2,3	2,6	1,90	695	76	66
3SIE315S6	75,0	100	992	94,6	95,0	94,7	722	0,82	242	147	139	7,1	2,4	2,6	2,40	900	77	67
3SIE315M6A	90,0	125	993	95,1	95,4	95,1	866	0,82	290	175	167	7,6	2,6	2,7	2,93	965	79	69
3SIE315M6B	110,0	150	992	95,2	95,6	95,2	1059	0,82	354	214	203	7,5	2,8	2,8	3,46	1110	79	69
3SIE315M6C	132,0	175	992	95,4	95,8	95,4	1271	0,83	-	253	241	7,0	2,5	2,5	4,21	1230	80	70
3SIE315M6D	160,0	220	992	95,2	95,7	95,6	1540	0,78	-	326	310	8,0	3,3	2,7	4,36	1235	80	70

* sprawność wyznaczona wg PN-EN 60034-2-1:2014 Pkt. 6.1.3 Metoda 2-1-1B- start poszczególnych, straty dodatkowe wg metody start resztkowych, efficiency is determinate acc. to IEC 60034-2-1:2014 Clause 6.1.3 Method 2-1-1B - summation of losses, additional losses acc. to the method of residual loss.

** 230V Δ/400V Y – standardowe silniki wielkości mech. 90÷100 400V Δ/690V Y – standardowe silniki wielkości mech. 112÷315
230V Δ/400V Y – standard motors size 90÷100 400V Δ/690V Y – standard motors size 112÷315

Producent zastrzega sobie prawo zmian parametrów zawartych w katalogu wynikających z ciągłego doskonalenia produktów bez wcześniejszego informowania.

As part of our development program, we reserve the rights to alert or amend any of the specifications without giving prior notice.

PARAMETRY EKSPLOATACYJNE SILNIKÓW O ZWIĘKSZONEJ MOCY PERFORMANCES OF MOTORS WITH INCREASED OUTPUT POWER

Typ silnika	Moc znamionowa P _N		Parametry przy obciążeniu znamionowym: Data of rated load:									Krotność (przy włączeniu bezpośrednim): Ratio of (at direct switching on):			Moment bezwładności J _M	Masa IM B3	Poziom mocy akustycz- nej przy 50Hz L _{WA}	Poziom ciśnienia akustycz- nego przy 50Hz L _{PA}
			Prędkość n _N	Sprawność [%] η _N IE3*			Moment M _N	Współ- czynnik mocy cos φ _N	Prąd znamionowy [A] I _N			Prądu rozruchowego do znamionowego I _L /I _N	Momentu rozruchowego do znamionowego M _L /M _N	Momentu maksymalnego do znamionowego M _B /M _N				
[kW]	[HP]	[min ⁻¹]		50%	75%	100%			[Nm]	[-]	230V Δ				380V**	400V**	[-]	[-]
Silniki 2-biegunowe, prędkość synchroniczna 3000 min ⁻¹ przy 50Hz 2-pole motors, synchronous speed 3000 min ⁻¹ at 50Hz																		
3SIE90L2A	3,0	4,0	2920	86,7	87,7	87,1	9,81	0,85	10,2	6,2	5,8	9,0	2,6	3,9	0,0019	20,5	75	63
3SIE100L2A	4,0	5,5	2920	88,1	88,8	88,1	13,1	0,85	13,4	8,1	7,7	9,0	3,2	4,1	0,0039	30	74	62
3SIE112M2A	5,5	7,5	2925	88,9	89,8	89,2	17,9	0,87	17,8	10,8	10,2	7,4	2,0	3,2	0,0075	39,5	74	61
3SIE112M2B	7,5	10,0	2930	90,9	91,1	90,1	24,4	0,87	24,0	14,5	13,8	8,4	2,5	3,5	0,0075	49	74	61
3SIE132M2	9,2	12,3	2935	90,5	91,2	90,7	29,9	0,88	28,9	17,5	16,6	9,7	3,2	3,8	0,020	73	80	68
3SIE132M2A	11,0	15,0	2925	92,1	91,9	91,2	35,9	0,89	34,1	20,6	19,6	8,1	2,6	3,8	0,021	76	80	68
3SIE160L2A	22,0	30,0	2950	91,9	92,8	92,7	71,2	0,89	66,9	40,5	38,5	9,7	3,2	3,8	0,072	148	82	69
3SIE200L2C	45,0	60,0	2962	94,5	94,6	94,0	145	0,90	134	81	77	7,3	2,6	2,5	0,21	301	88	78
3SIE200L2D	55,0	75,0	2950	95,2	95,2	94,3	178	0,90	163	98	94	6,4	2,3	2,6	0,24	322	88	78
3SIE225M2C	55,0	75,0	2970	94,8	95,0	94,5	177	0,89	164	99	94	7,1	2,1	3,1	0,33	425	90	80
3SIE250M2C	75,0	100,0	2969	94,3	94,8	94,7	241	0,88	226	137	130	7,2	2,3	3,2	0,42	498	87	77
3SIE280M2C	110,0	150,0	2978	95,4	95,6	95,2	353	0,92	315	191	181	6,9	1,9	2,9	0,98	748	92	82
3SIE280M2D	132,0	175,0	2977	95,8	95,9	95,6	423	0,92	377	228	217	7,3	2,0	2,7	1,28	864	92	82
Silniki 4-biegunowe, prędkość synchroniczna 1500 min ⁻¹ przy 50Hz 4-pole motors, synchronous speed 1500 min ⁻¹ at 50Hz																		
3SIE90L4A	2,2	3,0	1455	84,8	86,7	86,7	14,4	0,77	8,3	5,0	4,8	8,1	2,9	3,9	0,004	25	66	54
3SIE100L4C	4,0	5,5	1465	85,6	87,7	88,6	26,1	0,79	14,3	8,7	8,2	8,3	3,0	4,1	0,0086	34	67	55
3SIE112M4A	5,5	7,5	1460	89,4	90,2	89,6	36,0	0,80	19,3	11,7	11,1	7,2	2,5	3,3	0,0115	54	70	58
3SIE132M4A	9,2	12,3	1460	91,0	91,5	91,0	60,2	0,83	30,6	18,5	17,6	9,0	3,1	4,1	0,050	93	72	60
3SIE132M4B	11,0	15,0	1460	91,7	92,1	91,4	72,0	0,83	36,4	22,0	20,9	9,5	3,2	4,4	0,057	97	72	60
3SIE160L4A	18,5	25,0	1475	91,8	92,7	92,6	119,8	0,81	61,9	37,5	35,6	8,5	3,0	3,5	0,118	150	74	61
3SIE200L4C	37,0	50,0	1475	93,2	93,5	93,9	240	0,86	115	70	66	6,7	2,3	2,7	0,38	330	80	70
3SIE200L4D	45,0	60,0	1481	93,5	94,1	94,2	290	0,85	141	85	81	7,3	2,6	3,3	0,49	367	80	70
3SIE225M4C	55,0	75,0	1484	93,6	94,6	94,6	354	0,86	170	103	98	7,1	2,1	2,9	0,66	431	73	63
3SIE250M4C	75,0	100,0	1483	94,5	94,9	95,0	483	0,90	220	133	127	6,8	2,3	3,0	1,15	553	85	75
3SIE280M4C	110,0	150,0	1488	95,1	95,5	95,4	706	0,90	322	195	185	6,6	2,0	2,4	2,25	839	87	77
Silniki 6-biegunowe, prędkość synchroniczna 1000 min ⁻¹ przy 50Hz 6-pole motors, synchronous speed 1000 min ⁻¹ at 50Hz																		
3SIE90L6A	1,5	2,0	940	81,2	81,7	82,5	15,2	0,70	6,5	3,9	3,7	4,7	2,5	3,0	0,0090	21	62	50
3SIE100L6A	2,2	3,0	960	84,2	84,7	84,3	21,9	0,73	9,0	5,4	5,2	6,5	2,9	3,6	0,0100	26	64	52
3SIE112M6A	3,0	4,0	960	86,0	86,7	85,6	29,7	0,75	11,7	7,1	6,7	5,5	1,5	2,3	0,0177	36	65	53
3SIE132M6C	7,5	10,0	965	88,4	89,5	89,1	74,2	0,76	27,8	16,8	16,0	7,7	3,1	3,8	0,0637	73	73	61
3SIE225M6C	37,0	50,0	991	91,8	92,8	93,3	357	0,77	129	78	74	8,6	2,4	2,6	1,09	432	74	64
3SIE250M6C	45,0	60,0	992	93,2	93,8	93,7	433	0,82	147	89	85	6,9	2,0	2,6	1,55	489	76	66
3SIE280M6C	75,0	100,0	992	94,6	95,0	94,7	722	0,82	242	147	139	7,1	2,4	2,6	2,40	785	77	67

* silnik na etapie budowy prototypu oraz badań

** sprawność wyznaczona wg PN-EN 60034-2-1:2014 Pkt. 6.1.3 Metoda 2-1-1B- start poszczególnych, straty dodatkowe wg metody start resztkowych, efficiency is determinate acc. to IEC 60034-2-1:2014 Clause 6.1.3 Method 2-1-1B - summation of losses, additional losses acc. to the method of residual loss.

*** 230V Δ/400V Y – standardowe silniki wielkości mech. 90÷100 400V Δ/690V Y – standardowe silniki wielkości mech. 112÷315
230V Δ/400V Y – standard motors size 90÷100 400V Δ/690V Y – standard motors size 112÷315

Producent zastrzega sobie prawo zmian parametrów zawartych w katalogu wynikających z ciągłego doskonalenia produktów bez wcześniejszego informowania.
As part of our development program, we reserve the rights to alert or amend any of the specifications without giving prior notice.

**Formy wykonania maszyn elektrycznych wirujących zgodne są z PN-EN-60034-7.
 Mounting arrangements according to standard IEC 60034-7**

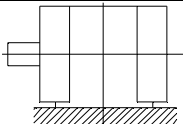
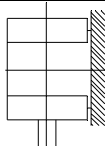
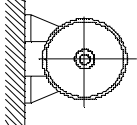
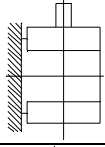
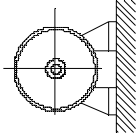
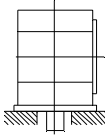
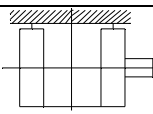
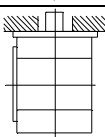
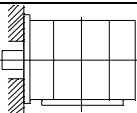
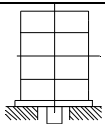
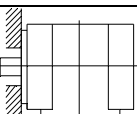
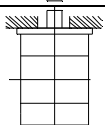
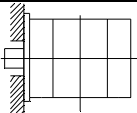
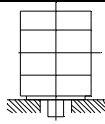
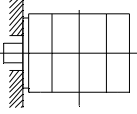
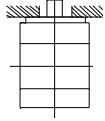
Walek poziomy/Horizontal shaft			Walek pionowy/Vertical shaft		
	Oznaczenie/Designaton			Oznaczenie/Designaton	
	System II	System I		System II	System I
	IM 1001 Standard	IM B3 Standard		IM 1011 Option*	IM V5 Option*
	IM 1051 Standard	IM B6 Standard		IM 1031 Option	IM V6 Option
	IM 1061 Standard	IM B7 Standard		IM 2011 Option*	IM V15 Option*
	IM 1071 Standard	IM B8 Standard		IM 2031 Option	IM V36 Option
	IM 2001 Standard	IM B35 Standard		IM 3011 Option*	IM V1 Option*
	IM 2101 Standard	IM B34 Standard		IM 3031 Option	IM V3 Option
	IM 3001 Standard	IM B5 Standard		IM 3611 Option*	IM V18 Option*
	IM 3601 Standard	IM B14 Standard		IM 3631 Option	IM V19 Option

* Silniki w wykonaniach IM 1011, IM 2011, IM 3011 oraz IM 3611 mogą mieć daszek ochronny.
 The motors versions IM 1011, IM 2011, IM 3011 and IM 3611 can have a protective cap.

DOPUSZCZALNE OBCIĄŻENIA KOŃCA WAŁU
PERMISSIBLE SHAFT END LOAD

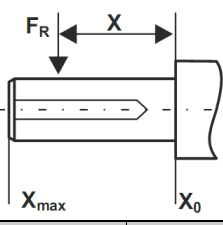
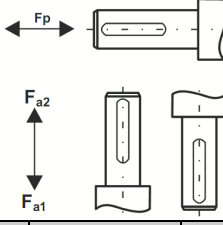
Typ silnika Motor type	Maksymalna siła promieniowa [kN] Maximum radial force [kN]		Maksymalna siła osiowa [kN] Maximum axial force [kN]		
					
	$F_R(x=0)$	$F_R(x=max)$	F_p	F_{a1}	F_{a2}
3SIE90S2	0,79	0,66	0,64	0,44	0,84
3SIE90L2	0,79	0,66	0,64	0,44	0,84
3SIE90L2A	0,79	0,66	0,64	0,44	0,84
3SIE90S4	1,00	0,83	0,80	0,65	1,05
3SIE90L4	1,00	0,83	0,80	0,65	1,05
3SIE90L4A	1,00	0,83	0,80	0,65	1,05
3SIE90S6	1,15	0,95	0,90	0,77	1,17
3SIE90L6	1,15	0,95	0,90	0,77	1,17
3SIE90L6A	1,15	0,95	0,90	0,77	1,17
3SIE100L2	1,11	0,89	0,90	0,61	1,17
3SIE100L2A	1,11	0,89	0,90	0,61	1,17
3SIE100L4A	1,39	1,12	1,12	0,90	1,46
3SIE100L4B	1,39	1,12	1,12	0,90	1,46
3SIE100L6	1,60	1,29	1,26	1,08	1,64
3SIE100L6A	1,60	1,29	1,26	1,08	1,64
3SIE112M2	1,56	1,22	1,23	0,84	1,60
3SIE112M2A	1,56	1,22	1,23	0,84	1,60
3SIE112M2B	1,56	1,22	1,23	0,84	1,60
3SIE112M4	1,92	1,58	1,50	1,19	1,96
3SIE112M4A	1,92	1,58	1,50	1,19	1,96
3SIE112M6	2,20	1,80	1,69	1,26	2,20
3SIE112M6A	2,20	1,80	1,69	1,26	2,20
3SIE132S2A	2,11	1,65	1,82	0,98	2,37
3SIE132S2B	2,11	1,65	1,82	0,98	2,37
3SIE132S2	2,11	1,65	1,82	0,98	2,37
3SIE132M2	2,11	1,65	1,82	0,98	2,37
3SIE132S4	2,67	2,08	2,31	1,36	3,00
3SIE132M4	2,67	2,08	2,31	1,36	3,00
3SIE132M4A	2,67	2,08	2,31	1,36	3,00
3SIE132M4B	2,67	2,08	2,31	1,36	3,00
3SIE132S6	3,06	2,39	2,51	1,40	3,26
3SIE132M6A	3,06	2,39	2,51	1,40	3,26
3SIE132M6B	3,06	2,39	2,51	1,40	3,26
3SIE132M6C	3,06	2,39	2,51	1,40	3,26
3SIE160M2A	2,43	1,88	1,97	1,00	2,56
3SIE160M2B	2,43	1,88	1,97	1,00	2,56
3SIE160L2	2,43	1,88	1,97	1,00	2,56
3SIE160M4	3,06	2,38	2,54	1,43	3,31
3SIE160L4	3,06	2,38	2,54	1,43	3,31
3SIE160M6	3,54	2,81	2,83	1,80	3,68
3SIE160L6	3,54	2,81	2,83	1,80	3,68
3SIE180M2	2,61	2,13	2,20	1,00	2,87
3SIE180M4	3,30	2,68	2,83	1,37	3,68
3SIE180L4	3,30	2,68	2,83	1,37	3,68
3SIE180L6	3,78	3,07	3,17	1,93	4,12

DOPUSZCZALNE OBCIĄŻENIA KOŃCA WAŁU
PERMISSIBLE SHAFT END LOAD

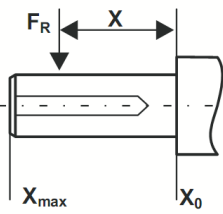
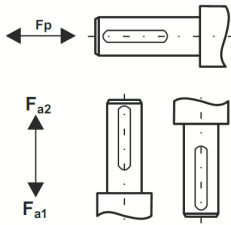
Typ silnika Motor type	Maksymalna siła promieniowa [kN] Maximum radial force [kN]		Maksymalna siła osiowa [kN] Maximum axial force [kN]		
					
	$F_R(x=0)$	$F_R(x=\max)$	F_p	F_{a1}	F_{a2}
3SIE200L2A	2,91	2,44	2,24	1,72	2,92
3SIE200L2B	2,85	2,39	2,23	1,67	2,93
3SIE200L2C	2,82	2,36	2,22	1,65	2,95
3SIE200L2D	2,69	2,26	2,18	1,57	2,97
3SIE200L4	3,61	3,03	2,81	2,12	3,70
3SIE200L4C	3,61	3,03	2,81	2,12	3,70
3SIE200L4D	3,34	2,80	2,73	1,90	3,80
3SIE200L6A	4,31	3,62	3,62	2,92	4,56
3SIE200L6B	4,06	3,40	3,54	2,71	4,65
3SIE225S4	4,18	3,40	3,19	2,42	4,16
3SIE225M2	3,31	2,81	2,53	1,93	3,29
3SIE225M2C	3,08	2,61	2,46	1,72	3,42
3SIE225M4	3,97	3,23	3,13	2,26	4,24
3SIE225M4C	3,83	3,12	3,09	2,14	4,30
3SIE225M6	4,57	3,72	3,98	2,95	5,33
3SIE225M6C	4,27	3,48	3,89	2,69	5,47
3SIE250M2	4,09	3,39	3,11	2,33	4,13
3SIE250M2C	4,09	3,39	3,11	2,33	4,13
3SIE250M4	4,90	4,06	3,85	2,68	5,36
3SIE250M4C	4,68	3,88	3,79	2,46	5,50
3SIE250M6	5,92	4,90	4,99	3,81	6,55
3SIE250M6C	5,55	4,60	4,87	3,43	6,77
3SIE280S2	3,94	3,34	3,07	2,01	4,43
3SIE280S4	6,69	5,67	5,01	3,65	6,77
3SIE280S6	7,86	6,67	5,79	4,32	7,70
3SIE280M2	3,80	3,22	3,03	1,89	4,49
3SIE280M2C	3,52	2,99	2,95	1,62	4,66
3SIE280M2D	2,94	2,50	2,79	1,02	5,06
3SIE280M4	6,15	5,22	4,86	3,16	7,04
3SIE280M4C	5,65	4,79	4,72	2,58	7,46
3SIE280M6	7,69	6,52	5,75	4,19	7,75
3SIE280M6C	7,10	6,02	5,58	3,52	8,22
3SIE315S2	3,56	3,08	2,96	1,63	4,69
3SIE315S4	5,75	4,82	4,74	2,71	7,37
3SIE315S6	7,21	6,04	5,61	3,84	8,14
3SIE315M2A	3,07	2,65	2,82	1,23	4,89
3SIE315M2B	2,67	2,31	2,71	0,91	5,05
3SIE315M4A	5,40	4,52	4,64	2,41	7,53
3SIE315M4B	5,16	4,33	4,58	2,20	7,64
3SIE315M6A	6,75	5,66	5,48	3,22	8,40
3SIE315M6B	6,27	5,33	5,34	2,68	8,78
3SIE315M2C	2,84	2,48	2,71	0,63	5,37
3SIE315M4C	6,27	5,33	4,34	1,46	8,06
3SIE315M6C	7,57	6,44	5,08	1,87	9,23
3SIE315M6D	7,47	6,36	5,05	1,82	9,22

KADŁUB, TARCZE ŁOŻYSKOWE, ŁAPY HAUSING, SHIELDS, FEET

Wielkość silnika Frame size	Tarcza kołnierkowa Flange B5	Kadłub silnika Housing	Tarcze łożyskowe End shields	Łapy Feet
3SIE90	Żeliwo / Cast iron	Aluminium	Aluminium	Aluminium – przykręcane / screwed
3SIE100	Żeliwo / Cast iron	Aluminium	Aluminium	Aluminium – przykręcane / screwed
3SIE112	Żeliwo / Cast iron	Aluminium	Żeliwo / Cast iron	Aluminium – przykręcane / screwed
3SIE132	Żeliwo / Cast iron	Aluminium	Żeliwo / Cast iron	Aluminium – przykręcane / screwed
3SIE160	Żeliwo / Cast iron	Żeliwo / Cast iron	Żeliwo / Cast iron	Żeliwo / Cast iron – przykręcane / screwed lub / or przyłane / integrated
3SIE180	Żeliwo / Cast iron	Żeliwo / Cast iron	Żeliwo / Cast iron	Żeliwo / Cast iron – przykręcane / screwed lub / or przyłane / integrated
3SIE200	Żeliwo / Cast iron	Żeliwo / Cast iron	Żeliwo / Cast iron	Żeliwo / Cast iron – przykręcane / screwed lub / or przyłane / integrated
3SIE225	Żeliwo / Cast iron	Żeliwo / Cast iron	Żeliwo / Cast iron	Żeliwo / Cast iron – przykręcane / screwed lub / or przyłane / integrated
3SIE250	Żeliwo / Cast iron	Żeliwo / Cast iron	Żeliwo / Cast iron	Żeliwo / Cast iron – przykręcane / screwed lub / or przyłane / integrated
3SIE280	Żeliwo / Cast iron	Żeliwo / Cast iron	Żeliwo / Cast iron	Żeliwo / Cast iron – przykręcane / screwed lub / or przyłane / integrated
3SIE315	Żeliwo / Cast iron	Żeliwo / Cast iron	Żeliwo / Cast iron	Żeliwo / Cast iron – przykręcane / screwed lub / or przyłane / integrated
3SIE315M6B, 6C,6D	Żeliwo / Cast iron	Żeliwo / Cast iron	Żeliwo / Cast iron	Żeliwo / Cast iron – przykręcane / screwed

TYP ŁOŻYSK ZASTOSOWANYCH W SILNIKACH TYPE OF BEARINGS USED IN MOTORS

Wielkość silnika Frame size	Liczba biegunów Number of poles	Łożyska Bearings
3SIE90	2 ÷ 6	6205 C3
3SIE100	2 ÷ 6	6206 C3
3SIE112	2 ÷ 6	6306 C3
3SIE132	2 ÷ 6	6308 C3
3SIE160	2 ÷ 6	6309 C3
3SIE180	2 ÷ 6	6311 C3
3SIE200	2 ÷ 6	6312 C3
3SIE225	2 ÷ 6	6313 C3
3SIE250	2 ÷ 6	6315 C3
3SIE280	2	6315 C3
3SIE280	4 ÷ 6	6318 C3
3SIE315S, MA, MB	2	6315 C3
3SIE315MC	2	6316 C3
3SIE315S, MA, MB	4 ÷ 6	6318 C3
3SIE315MC, MD	4 ÷ 6	6320C3/6318C3

Wymiary silników na łapach B3

Dimensions for foot-mounted motors B3

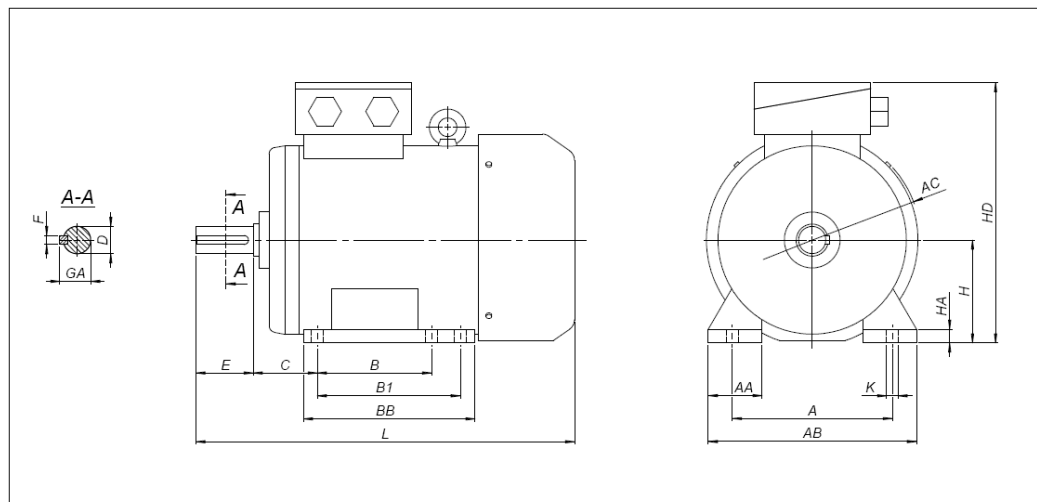

Type of motor	A	B	B1	C	D	E	F	GA	H	HA	K	AA	AB	AC	BB	HD	L
3SIE90S2,4,6	140	100	125	56	24	50	8	27	90	10	10	47	182	200	153	238	331
3SIE90L2	140	100	125	56	24	50	8	27	90	10	10	47	182	200	153	238	331
3SIE90L2A,4,6,	140	100	125	56	24	50	8	27	90	10	12	47	182	200	153	238	356
3SIE90L4A,6A**	140	100	125	56	24	50	8	27	90	10	12	47	182	200	153	238	
3SIE100L2,6	160	140	-	63	28	60	8	31	100	12	12	52	202	215	170	257	377
3SIE100L2A,4A,4B,6A	160	140	-	63	28	60	8	31	100	12	12	52	202	215	170	257	417
3SIE100L4C**	160	140	-	63	28	60	8	31	100	12	12	52	202	215	170	257	
3SIE112M2,6	190	140	-	70	28	60	8	31	112	14	12	52	222	248	170	280	398
3SIE112M2A,4,6A	190	140	-	70	28	60	8	31	112	14	12	52	222	248	170	280	425
3SIE112M2B,4A	190	140	-	70	28	60	8	31	112	14	12	52	222	248	170	280	485
3SIE132S2A,2B,4,6	216	140	178	89	38	80	10	41	132	18	12	61	266	288	220	329	512
3SIE132S2	216	140	178	89	38	80	10	41	132	18	12	61	266	288	220	329	542
3SIE132M4,6A,6B	216	140	178	89	38	80	10	41	132	18	12	61	266	288	220	329	512
3SIE132M2,2A,4A,4B,6C	216	140	178	89	38	80	10	41	132	18	12	61	266	288	220	329	542
3SIE160M2A,2B,4,6	254	210	254	108	42	110	12	45	160	25	15	81	320	340	300	383	643
3SIE160L2,4,6	254	210	254	108	42	110	12	45	160	25	15	81	320	340	300	383	643
3SIE180M2,4	279	241	279	121	48	110	14	51,5	180	27	15	92	353	360	320	414	723
3SIE180L4,6	279	241	279	121	48	110	14	51,5	180	27	15	92	353	360	320	414	723
3SIE200L2A,B,C,D; L4,C,D; L6A,B	318	305	-	133	55	110	16	59	200	32	19	80	400	455	380	520	850
3SIE225S4	356	286	311	149	60	140	18	64	225	34	19	85	440	500	380	570	930
3SIE225M2,C	356	286	311	149	55	110	16	59	225	34	19	85	440	500	380	570	900
3SIE225M4,C; M6,C	356	286	311	149	60	140	18	64	225	34	19	85	440	500	380	570	930
3SIE250M2,C	406	349	-	168	60	140	18	64	250	37	24	90	480	545	445	635	1010
3SIE250M4,C; M6,C	406	349	-	168	65	140	18	69	250	37	24	90	480	545	445	635	1040
3SIE280S2	457	368	419	190	65	140	18	69	280	40	24	105	550	600	520	720	1135
3SIE280S4; S6	457	368	419	190	75	140	20	79,5	280	40	24	105	550	600	520	720	1135
3SIE280M2,C,D	457	368	419	190	65	140	18	69	280	40	24	105	550	600	520	720	1135
3SIE280M4,C; M6,C	457	368	419	190	75	140	20	79,5	280	40	24	105	550	600	520	720	1135
3SIE315S2	508	406	457	216	65	140	18	69	315	48	28	120	610	630	565	805	1235
3SIE315S4; S6	508	406	457	216	80	170	22	85	315	48	28	120	610	630	565	805	1265
3SIE315M2A	508	406	457	216	65	140	18	69	315	48	28	120	610	630	565	805	1235
3SIE315M2B	508	406	457	216	65	140	18	69	315	48	28	120	610	630	565	805	1235
3SIE315M4A; 6A	508	406	457	216	80	170	22	85	315	48	28	120	610	630	565	805	1265
3SIE315M4B	508	406	457	216	80	170	22	85	315	48	28	120	610	630	565	805	1265
3SIE315M6B	508	406	457	216	80	170	22	85	315	48	28	135	610	630	600	805	1355
3SIE315M2C	508	406	457	216	70	140	20	74,5	315	48	28	135	610	630	600	805	1290
3SIE315M4C	508	406	457	216	80	170	22	85	315	48	28	135	610	630	600	805	1320
3SIE315M6C	508	406	457	216	80	170	22	85	315	48	28	135	610	630	600	805	1320
3SIE315M6D	508	406	457	216	90	170	25	95	315	48	28	135	610	630	600	805	1320

** silniki w fazie testów / prototypes made only

Producent zastrzega sobie prawo zmian wymiarów gabarytowych przedstawionych w katalogu.

The manufacturer reserves the right to modify the overall dimensions of the products shown in this catalogue.

Wymiary silników kołnierzowych B5

Dimensions for flange-mounted motors B5

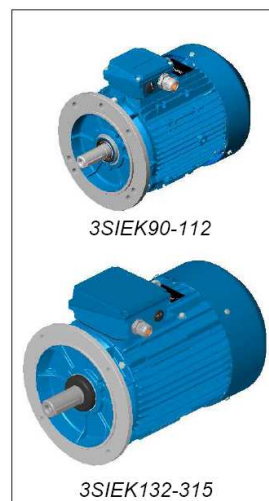
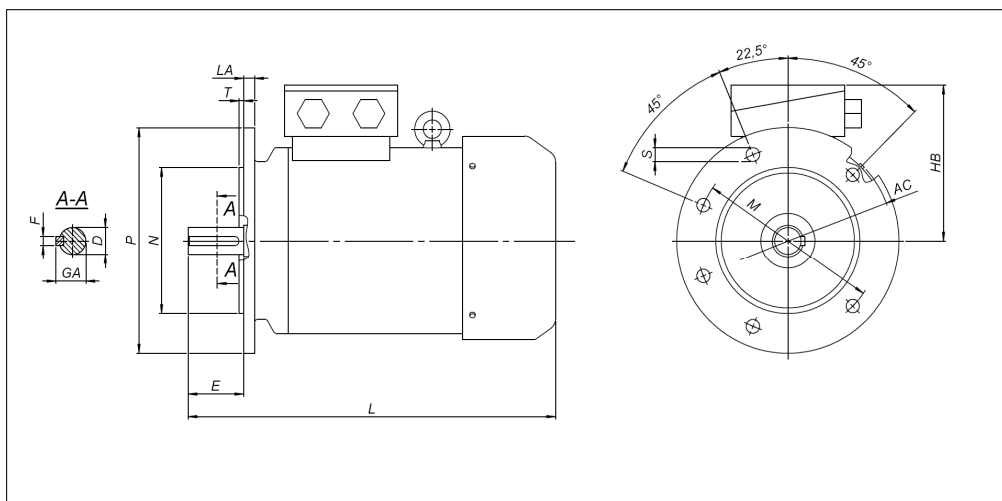

Type of motor	D	E	F	GA	AC	HB	L	LA	M	N	P	T	S	
													∅	holes
3SIEK90S2,4,6,L2	24	50	8	27	200	148	331	8	165	130	200	3,5	12	4
3SIEK90L2A,4,6	24	50	8	27	200	148	356	8	165	130	200	3,5	12	4
3SIEK90L4A,6A**	24	50	8	27	200	148		8	165	130	200	3,5	12	4
3SIEK100L2,6	28	60	8	31	215	157	377	11	215	180	250	4	15	4
3SIEK100L2A,4A,4B,6A	28	60	8	31	215	157	417	11	215	180	250	4	15	4
3SIEK100L4C**	28	60	8	31	215	157		11	215	180	250	4	15	4
3SIEK112M2,6	28	60	8	31	248	168	398	12	215	180	250	4	15	4
3SIEK112M2A,M4,6A	28	60	8	31	248	168	425	12	215	180	250	4	15	4
3SIEK112M2B,4A	28	60	8	31	248	168	485	12	215	180	250	4	15	4
3SIEK132S2A,2B,4,6	38	80	10	41	288	197	512	12	265	230	300	4	15	4
3SIEK132S2	38	80	10	41	288	197	542	12	265	230	300	4	15	4
3SIEK132M4,6A,6B	38	80	10	41	288	197	512	12	265	230	300	4	15	4
3SIEK132M2,2A,4A,4B,6C	38	80	10	41	288	197	542	12	265	230	300	4	15	4
3SIEK160M2A,2B,4,6	42	110	12	45	340	223	643	13	300	250	350	5	19	4
3SIEK160L2,4,6	42	110	12	45	340	223	643	13	300	250	350	5	19	4
3SIEK180M2,4	48	110	14	51,5	360	234	723	13	300	250	350	5	19	4
3SIEK180L4,6	48	110	14	51,5	360	234	723	13	300	250	350	5	19	4
3SIEK200L2A,B,C,D; L4,C,D; L6A,B	55	110	16	59	455	320	850	16,5	350	300	400	5	19	4
3SIEK225S4	60	140	18	64	500	345	930	18	400	350	450	5	19	8
3SIEK225M2,C	55	110	16	59	500	345	900	18	400	350	450	5	19	8
3SIEK225M4,C; M6,C	60	140	18	64	500	345	930	18	400	350	450	5	19	8
3SIEK250M2,C	60	140	18	64	545	385	1010	23	500	450	550	5	19	8
3SIEK250M4,C; M6,C	65	140	18	69	545	385	1040	23	500	450	550	5	19	8
3SIEK280S2	65	140	18	69	600	440	1135	23	500	450	550	5	19	8
3SIEK280S4; S6	75	140	20	79,5	600	440	1135	23	500	450	550	5	19	8
3SIEK280M2,C,D	65	140	18	69	600	440	1135	23	500	450	550	5	19	8
3SIEK280M4,C; M6,C	75	140	20	79,5	600	440	1135	23	500	450	550	5	19	8
3SIEK315S2	65	140	18	69	630	490	1235	23	600	550	660	6	24	8
3SIE315S4; S6	80	170	22	85	630	490	1265	23	600	550	660	6	24	8
3SIEK315M2A	65	140	18	69	630	490	1235	23	600	550	660	6	24	8
3SIEK315M2B	65	140	18	69	630	490	1235	23	600	550	660	6	24	8
3SIEK315M4A; 6A	80	170	22	85	630	490	1265	23	600	550	660	6	24	8
3SIEK315M4B	80	170	22	85	630	490	1265	23	600	550	660	6	24	8
3SIEK315M6B*	80	170	22	85	630	490	1355	23	600	550	660	6	24	8
3SIEK315M2C*	70	140	20	74,5	630	490	1290	23	600	550	660	6	24	8
3SIEK315M4C*	80	170	22	85	630	490	1320	23	600	550	660	6	24	8
3SIEK315M6C*	80	170	22	85	630	490	1320	23	600	550	660	6	24	8
3SIEK315M6D*	90	170	25	95	630	490	1320	23	600	550	660	6	24	8

* only in vertical position IMV1

** silniki w fazie testów / prototypes made only

Producent zastrzega sobie prawo zmian wymiarów gabarytowych przedstawionych w katalogu.

The manufacturer reserves the right to modify the overall dimensions of the products shown in this catalogue.

Wymiary silników kołnierzowych na łapach B35

Dimensions for foot-flange-mounted motors B35

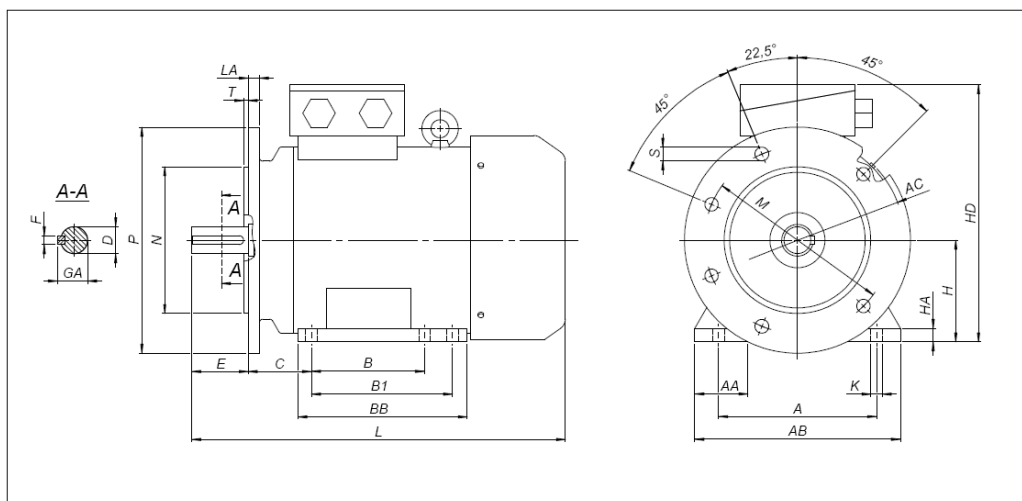

Type of motor	A	B	B1	C	D	E	F	GA	H	HA	K	AA	AB	AC	BB	HD	L	LA	M	N	P	T	S	
																							∅	holes
3SIEL90S2,4,6	140	100	125	56	24	50	8	27	90	10	10	47	182	200	153	238	331	8	165	130	200	3,5	12	4
3SIEL90L2	140	125	125	56	24	50	8	27	90	10	10	47	182	200	153	238	331	8	165	130	200	3,5	12	4
3SIEL90L2A,4,6	140	125	-	56	24	50	8	27	90	10	12	47	182	200	153	238	356	8	165	130	200	3,5	12	4
3SIEL90L4A,6A**	140	125	-	56	24	50	8	27	90	10	12	47	182	200	153	238		8	165	130	200	3,5	12	4
3SIEL100L2,6	160	140	-	63	28	60	8	31	100	12	12	52	202	215	170	257	377	11	215	180	250	4	15	4
3SIEL100L2A,4A,4B,6A	160	140	-	63	28	60	8	31	100	12	12	52	202	215	170	257	417	11	215	180	250	4	15	4
3SIEL100L4A**	160	140	-	63	28	60	8	31	100	12	12	52	202	215	170	257		11	215	180	250	4	15	4
3SIEL112M2,6	190	140	-	70	28	60	8	31	112	14	12	52	222	248	170	280	398	12	215	180	250	4	15	4
3SIEL112M2A,4,6A	190	140	178	70	28	60	8	31	112	14	12	52	222	248	170	280	425	12	215	180	250	4	15	4
3SIEL112M2B,4A	190	140	178	70	28	60	8	31	112	14	12	52	222	248	170	280	485	12	215	180	250	4	15	4
3SIEL132S2A,2B,4,6	216	140	178	89	38	80	10	41	132	18	12	61	266	288	220	329	512	12	265	230	300	4	15	4
3SIEL132S2	216	140	178	89	38	80	10	41	132	18	12	61	266	288	220	329	542	12	265	230	300	4	15	4
3SIEL132M4,6A,6B	216	178	178	89	38	80	10	41	132	18	12	61	266	288	220	329	512	12	265	230	300	4	15	4
3SIEL132M2,2A,4A,4B,6C	216	178	254	89	38	80	10	41	132	18	12	61	266	288	220	329	542	12	265	230	300	4	15	4
3SIEL160M2A,2B,4,6	254	210	254	108	42	110	12	45	160	25	15	81	320	340	300	383	643	13	300	250	350	5	19	4
3SIEL160L2,4,6	254	254	279	108	42	110	12	45	160	25	15	81	320	340	300	383	643	13	300	250	350	5	19	4
3SIEL180M2,4	279	241	279	121	48	110	14	51,5	180	27	15	92	353	360	320	414	723	13	300	250	350	5	19	4
3SIEL180L4,6	279	279	-	121	48	110	14	51,5	180	27	15	92	353	360	320	414	723	13	300	250	350	5	19	4
3SIEL200L2A,B,C,D; L4,C,D; L6A,B	318	305	311	133	55	110	16	59	200	32	19	80	400	455	380	520	850	16,5	350	300	400	5	19	4
3SIEL225S4	356	286	311	149	60	140	18	64	225	34	19	85	440	500	380	570	930	18	400	350	450	5	19	8
3SIEL225M2,C	356	286	311	149	55	110	16	59	225	34	19	85	440	500	380	570	900	18	400	350	450	5	19	8
3SIEL225M4,C; M6,C	356	286	-	149	60	140	18	64	225	34	19	85	440	500	380	570	930	18	400	350	450	5	19	8
3SIEL250M2,C	406	349	-	168	60	140	18	64	250	37	24	90	480	545	445	635	1010	23	500	450	550	5	19	8
3SIEL250M4,C; M6,C	406	349	419	168	65	140	18	69	250	37	24	90	480	545	445	635	1040	23	500	450	550	5	19	8
3SIEL280S2	457	368	419	190	65	140	18	69	280	40	24	105	550	600	520	720	1135	23	500	450	550	5	19	8
3SIEL280S4; S6	457	368	419	190	75	140	20	79,5	280	40	24	105	550	600	520	720	1135	23	500	450	550	5	19	8
3SIEL280M2,C,D	457	368	419	190	65	140	18	69	280	40	24	105	550	600	520	720	1135	23	500	450	550	5	19	8
3SIEL280M4,C; M6,C	457	368	457	190	75	140	20	79,5	280	40	24	105	550	600	520	720	1135	23	500	450	550	5	19	8
3SIEL315S2	508	406	457	216	65	140	18	69	315	48	28	120	610	630	565	805	1235	23	600	550	660	6	24	8
3SIEL315S4; S6	508	406	457	216	80	170	22	85	315	48	28	120	610	630	565	805	1265	23	600	550	660	6	24	8
3SIEL315M2A	508	406	457	216	65	140	18	69	315	48	28	120	610	630	565	805	1235	23	600	550	660	6	24	8
3SIEL315M2B	508	406	457	216	65	140	18	69	315	48	28	135	610	630	565	805	1235	23	600	550	660	6	24	8
3SIEL315M4A, 6A	508	406	457	216	80	170	22	85	315	48	28	120	610	630	565	805	1265	23	600	550	660	6	24	8
3SIEL315M4B	508	406	457	216	80	170	22	85	315	48	28	120	610	630	565	805	1265	23	600	550	660	6	24	8
3SIEL315M6B	508	406	457	216	80	170	22	85	315	48	28	135	610	630	600	805	1355	23	600	550	660	6	24	8
3SIEL315M2C	508	406	457	216	70	140	20	74,5	315	48	28	135	610	630	600	805	1290	23	600	550	660	6	24	8
3SIEL315M4C	508	406	457	216	80	170	22	85	315	48	28	135	610	630	600	805	1320	23	600	550	660	6	24	8
3SIEL315M6C	508	406	457	216	80	170	22	85	315	48	28	135	610	630	600	805	1320	23	600	550	660	6	24	8
3SIEL315M6D	508	406	457	216	90	170	25	95	315	48	28	135	610	630	600	805	1320	23	600	550	660	6	24	8

** silniki w fazie testów / prototypes made only

Producent zastrzega sobie prawo zmian wymiarów gabarytowych przedstawionych w katalogu.

The manufacturer reserves the right to modify the overall dimensions of the products shown in this catalogue.

Wymiary silników z tarczą kołnierkową B14

Dimensions for motors with flange B14

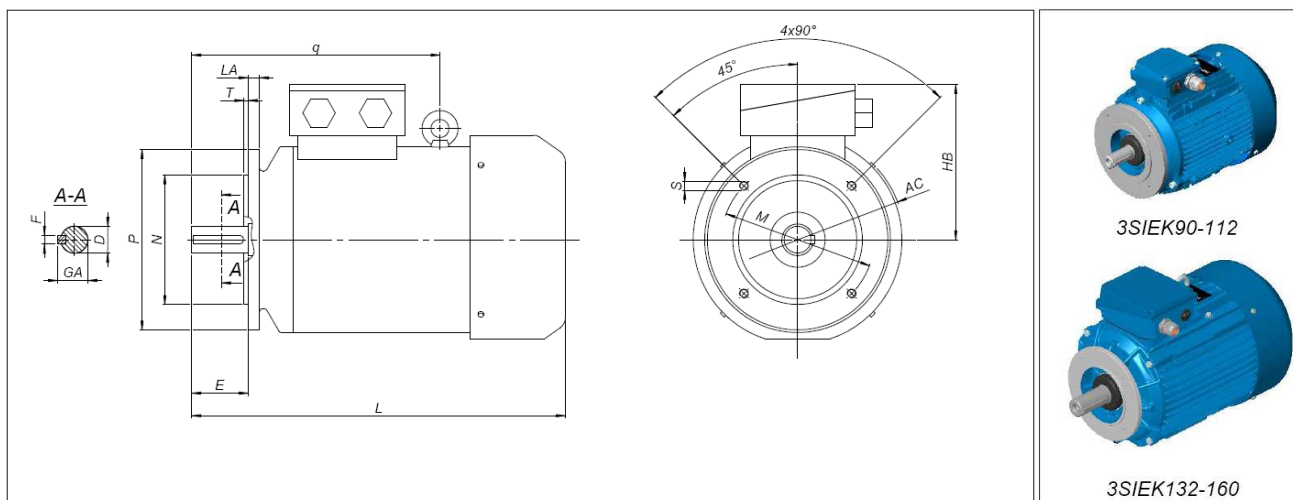

Type of motor	D	E	F	GA	AC	HB	L	LA	Kołnierż Flange	M	N	P	T	S	
														Ø	holes
3SIEK90S2,4,6,L2	24	50	8	27	200	148	331	10	FT130/C160	130	110	160	3,5	M8	4
									FT115/C140	115	95	140	3,0	M8	4
3SIEK90L2A,4,6	24	50	8	27	200	148	356	10	FT130/C160	130	110	160	3,5	M8	4
									FT115/C140	115	95	140	3,0	M8	4
3SIEK90L4A,6A**	24	50	8	27	200	148		10	FT130/C160	130	110	160	3,5	M8	4
									FT115/C140	115	95	140	3,0	M8	4
3SIEK100L2,6	28	60	8	31	215	157	377	12	FT165/C200	165	130	200	3,5	M10	4
									FT130/C160	130	110	160	3,5	M8	4
3SIEK100L2A,4A,4B,6A	28	60	8	31	215	157	417	12	FT165/C200	165	130	200	3,5	M10	4
									FT130/C160	130	110	160	3,5	M8	4
3SIEK100L4C**	28	60	8	31	215	157		12	FT165/C200	165	130	200	3,5	M10	4
									FT130/C160	130	110	160	3,5	M8	4
3SIEK112M2,6	28	60	8	31	248	168	398	12	FT165/C200	165	130	200	3,5	M10	4
									FT130/C160	130	110	160	3,5	M8	4
3SIEK112M2A,4,6C	28	60	8	31	248	168	425	12	FT165/C200	165	130	200	3,5	M10	4
									FT130/C160	130	110	160	3,5	M8	4
3SIEK112M2B,4A	28	60	8	31	248	168	485	12	FT165/C200	165	130	200	3,5	M10	4
									FT130/C160	130	110	160	3,5	M8	4
3SIEK132S2A,2B,4,6	38	80	10	41	288	197	512	12	FT215/C250	215	180	250	4,0	M12	4
									FT165/C200	165	130	200	3,5	M10	4
3SIEK132S2	38	80	10	41	288	197	542	12	FT215/C250	215	180	250	4,0	M12	4
									FT165/C200	165	130	200	3,5	M10	4
3SIEK132M4,6A,6B	38	80	10	41	288	197	512	12	FT215/C250	215	180	250	4,0	M12	4
									FT165/C200	165	130	200	3,5	M10	4
3SIEK132M2,2A,4A,4B,6C	38	80	10	41	288	197	542	12	FT215/C250	215	180	250	4,0	M12	4
									FT165/C200	165	130	200	3,5	M10	4
3SIEK160M2A,2B,4,6	42	110	12	45	340	223	643	13	FT265/C300	265	230j6	300	4,0	M12	4
									FT215/C250	215	180j6	250	4,0	M12	4
3SIEK160L2,4,6	42	110	12	45	340	223	643	13	FT265/C300	265	230j6	300	4,0	M12	4
									FT215/C250	215	180j6	250	4,0	M12	4

** silniki w fazie testów / prototypes made only

Wymiary silników kołnierżowych na łapach IM B34 (oprócz tarczy kołnierżowej) –

patrz tabele dla IM 2001/B35 na stronie 12

Dimensions for foot-flange motors IM B34 (except flange shield) – see tables for IM 2001/B35 on page 12

Producent zastrzega sobie prawo zmian wymiarów gabarytowych przedstawionych w katalogu.

The manufacturer reserves the right to modify the overall dimensions of the products shown in this catalogue

WIELKOŚĆ MECHANICZNA: 90÷180
FRAME SIZE: 90÷180

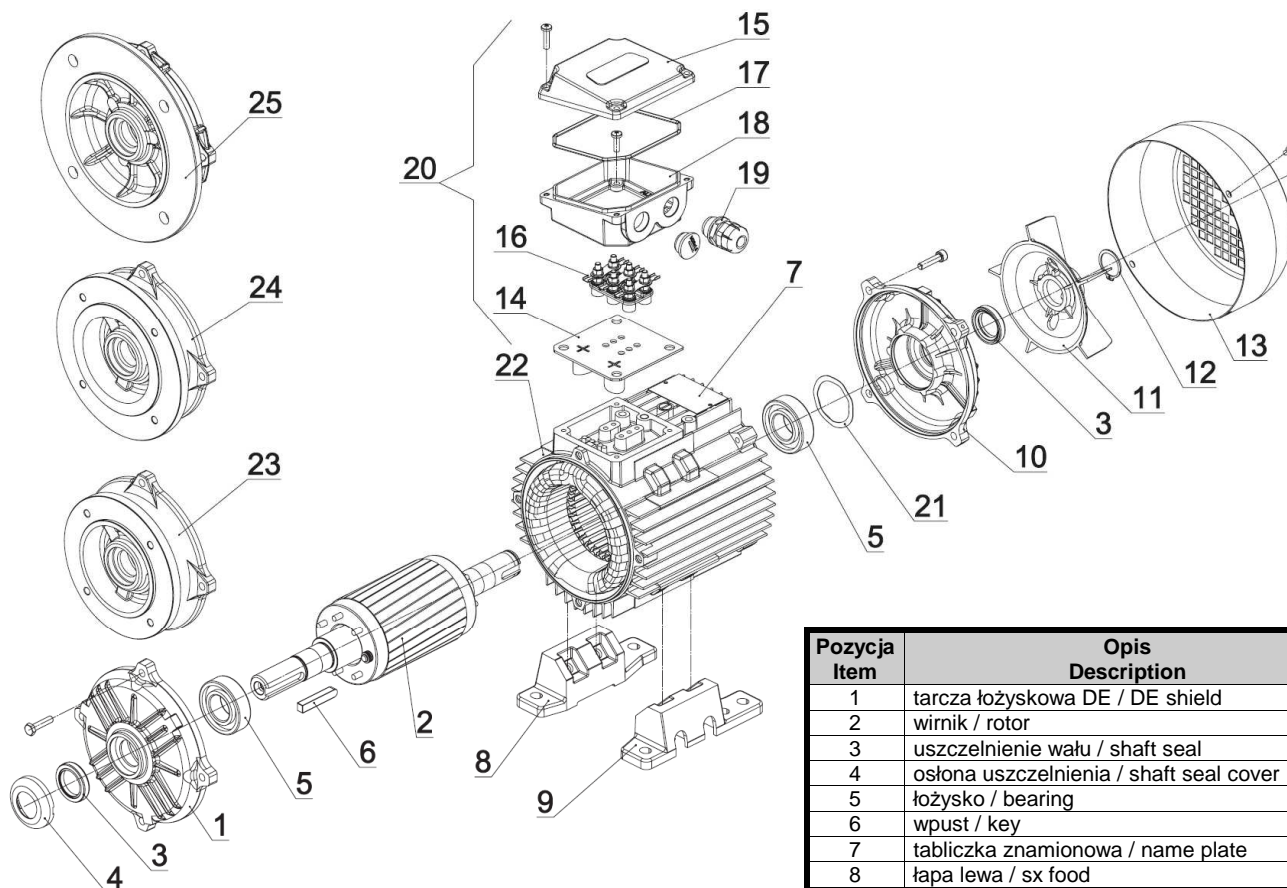

Pozycja Item	Opis Description
1	tarcza łożyskowa DE / DE shield
2	wirnik / rotor
3	uszczelnienie wału / shaft seal
4	osłona uszczelnienia / shaft seal cover
5	łożysko / bearing
6	wpust / key
7	tabliczka znamionowa / name plate
8	łapa lewa / sx food
9	łapa prawa / dx food
10	tarcza łożyskowa NDE / NDE shield
11	przewietrznik / fan
12	pierścień osadczy / seeger ring
13	osłona przewietrznika / fan cover
14	uszczelka skrzynki / rubber gasket
15	pokrywa skrzynki / terminal box cover
16	tabliczka zaciskowa / terminal board
17	uszczelka pokrywy / rubber gasket
18	skrzynka zaciskowa / terminal box
19	dławnica / gland
20	skrz. zacisk. zestaw / terminal box complete
21	podkładka falista / spring washer
22	stojan / stator
23(1)	tarcza kołnierзова B14/C2 / flange B14/C2
24(1)	tarcza kołnierзова B14/C1 / flange B14/C1
25	tarcza kołnierзова B5 / flange B5

1 – tylko dla silników wielkości mechanicznej 90 – 132
only for frame size 90 – 132

DE – strona napędowa / drive end
NDE – strona przeciwnapędowa / non drive end

WIELKOŚĆ MECHANICZNA: 200÷315
FRAME SIZE: 200÷315

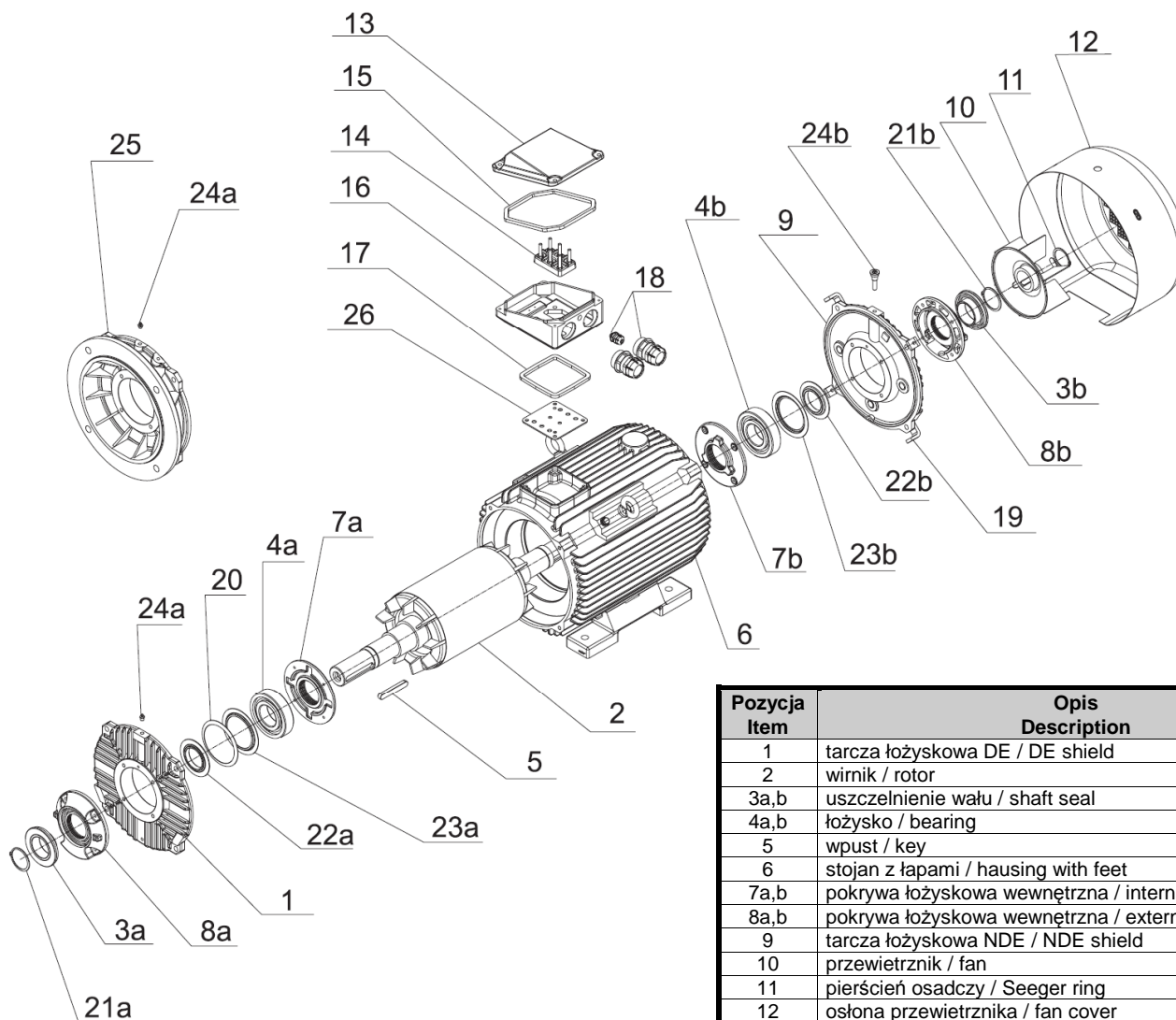

Pozycja Item	Opis Description
1	tarcza łożyskowa DE / DE shield
2	wirnik / rotor
3a,b	uszczelnienie wału / shaft seal
4a,b	łożysko / bearing
5	wpust / key
6	stojan z łapami / housing with feet
7a,b	pokrywa łożyskowa wewnętrzna / internal bearing cap
8a,b	pokrywa łożyskowa zewnętrzna / external bearing cap
9	tarcza łożyskowa NDE / NDE shield
10	przewietrznik / fan
11	pierścień osadczy / Seeger ring
12	osłona przewietrznika / fan cover
13	pokrywa skrzynki / terminal box cover
14	tabliczka zaciskowa / terminal board
15	uszczelka pokrywy / rubber gasket
16	skrzynka zaciskowa / terminal box
17	uszczelka skrzynki / rubber gasket
18	dławnica / glands
19	mocownik osłony przewietrznika / fan cover support
20	podkładka falista / spring washer
21a,b	pierścień osadczy / seeger ring
22a,b	odrzutnik smaru / grease shield
23a,b	pierścień łożyskowy wewnętrzny / bearing internal ring
24a,b	smarowniczką / grease nipple
25	tarcza kołnierzowa B5 / flange B5
26	uszczelka skrzynki / rubber gasket

DE – strona napędowa / drive end

NDE – strona przeciwnapędowa / non drive end